



Blum, Inc. is a leading manufacturer of functional hardware for the cabinet and furniture industry specializing in concealed hinges and drawer runner systems. Virtually all of the hardware needed to assemble and make casegoods functional are available within the wide range of lifetime guaranteed Blum products.

Blum's manufacturing and distribution complex in Stanley, North Carolina supplies the North American markets through a network of more than 150 dependable distributors. Wholly owned by the Blum family, the company was formed in 1952 by Julius Blum and is headquartered in Hoechst, Austria.

#### Global customer benefits

Product development at Blum considers all of the various customers who will come in contact with our products. With this "Global Customer Benefits" philosophy we strive to create advantages for all users from the cabinetmaker to the end consumer.

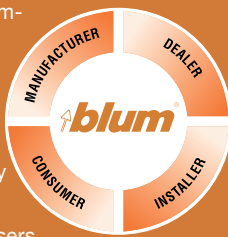

Blum, Inc. is ISO 9001 certified which means that you are assured of consistent quality in every Blum product. As with all Blum hardware, STANDARD drawer runners are backed with a lifetime guarantee. What's more they exceed the requirements of ANSI-BHMA standards for cycle life, static load and self-closing performance. Contact your local Blum representative for more details.



### The STANDARD drawer runner series

Blum STANDARD drawer runners apply proven technology built upon years of experience to ensure a solid performance that will last a lifetime. The program is designed for a variety of applications including shelf pull-outs to full extension for access to the entire drawer.

The STANDARD drawer runner series is the runner of choice when performance, function and durability are desired. Blum offers three series of conventional drawer runners that deliver exceptional running action.

The 230M is a single extension bottom mounted drawer runner with Blumatic self-closing action. The durable epoxy coated steel profiles are available in lengths from 10" to 26" with cabinet profiles compatible to the 32mm line bore pattern.

The 230E single extension series is made for extremely long drawers. It is available in 28" to 32" lengths. Both the 230M and 230E series can be installed in frame cabinets with optional rear mount sockets.

The 430E full extension series is available in lengths from 10" to 32". The series features a safety lock to prevent accidental drawer removal and an intermediate profile lockout for easy drawer insertion.

All STANDARD drawer runners exceed BHMA Grade 1 requirements (75 lbs. dynamic load capacity, and 100 lbs. static load capacity). STANDARD drawer runners are backed by Blum's Lifetime Guarantee.

### Table of Contents

<b>STANDARD Drawer Runner Program</b>	<b>3</b>
<b>230M Series</b>	<b>4 - 5</b>
<b>230E Series</b>	<b>6 - 7</b>
<b>430E Series</b>	<b>8 - 9</b>
<b>430E Assembly</b>	<b>10</b>
<b>STANDARD Accessories</b>	<b>11 - 12</b>
<b>Unique Applications</b>	<b>13</b>
<b>DynaPlan Software Program</b>	<b>15</b>

### Testing standards at Blum

#### Dynamic wear test

100,000 open/close cycles with a total weight of 75 lbs on a 22" drawer.

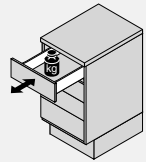

#### Static loading test

100 lbs applied to a half extended 22" drawer for 1 minute.

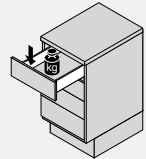

#### Side pressure test

A force of 33 lbs is applied ten times to a fully extended 22" drawer.

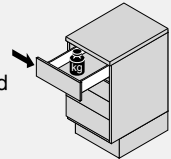



# Standard drawer runner program

## 230M Single extension, Blumatic self-closing drawer runners

Lengths: 250mm (10") to 650mm (26")

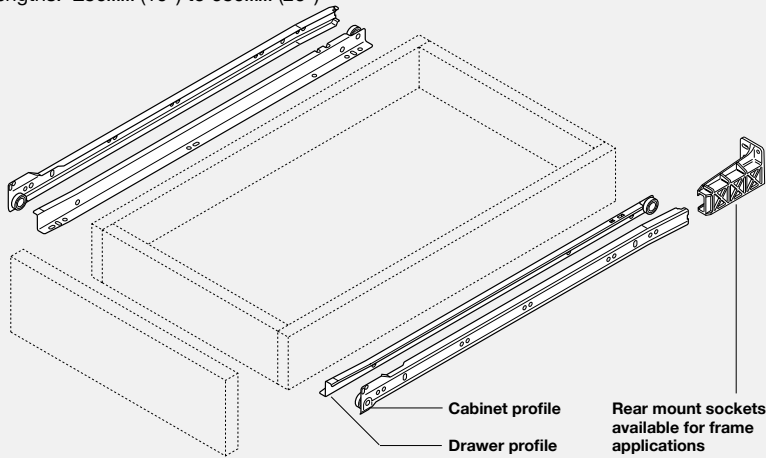

## 230 series drawer runners



- Single extension, bottom mounted
- Durable epoxy coating in cream or white
- Smooth running synthetic rollers on tempered steel axles
- Captive RH profiles/tolerance LH profiles
- 1/2" side clearance
- Double warning lift out stop

**230M** series have Blumatic self-closing action. Angled drawer and cabinet profiles create a parallel drop 3/32".

**230E** series have stay-closed detents in the drawer profiles that hold the drawer in the closed position.

## 230E Single extension drawer runners with stay-closed detents

Lengths: 700mm (28") to 800mm (32")

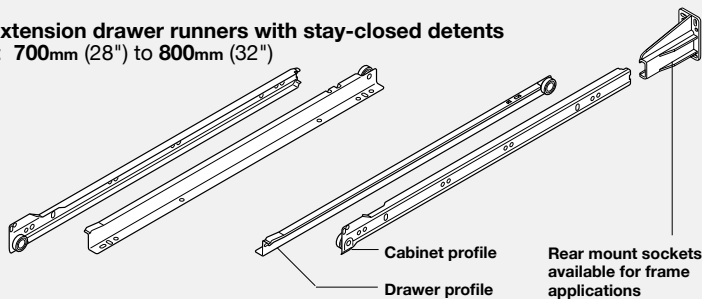

## 430E Full extension drawer runners with stay-closed detents

Lengths: 250mm (10") to 800mm (32")

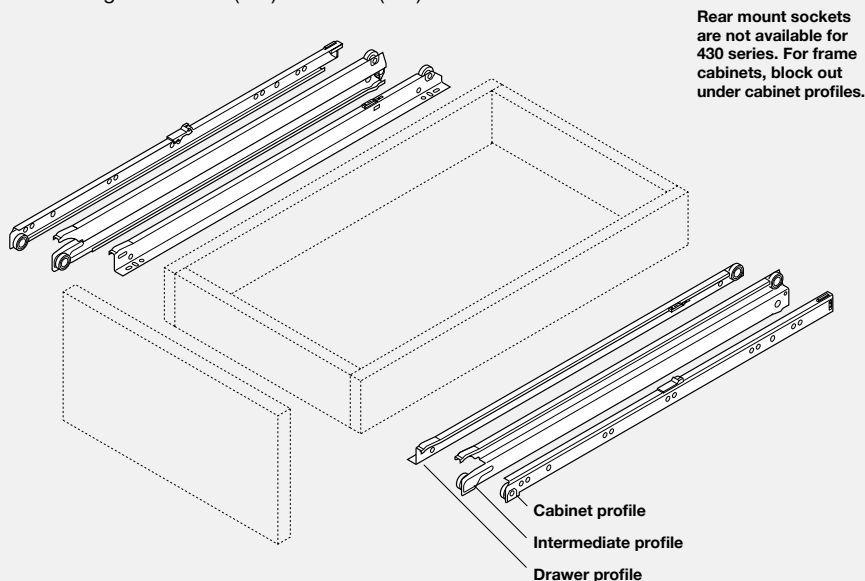

## 430 series drawer runners



- Full extension, bottom mounted
- Durable epoxy coating in cream or white
- Smooth running synthetic rollers on tempered steel axles
- Double captive profiles
- 1/2" side clearance
- Lock out stops to prevent drawer removal
- Intermediate profiles lock out for easy drawer installation
- 1-1/4" over extension
- Detents in the drawer and intermediate profiles hold the drawer closed

### Millimeter to inch equivalents

1	1.5	2	3	4	5	5.5	6	7	8	9	9.5	10	11	12	13	13.5	14	15	16	17	17.5	18	19	20	20.5	21	22	23	24	24.5	25.4
1/32	1/16	3/32	1/8	5/32	3/16	7/32	1/4	9/32	5/16	11/32	3/8	13/32	7/16	15/32	1/2	17/32	9/16	19/32	5/8	21/32	11/16	23/32	3/4	25/32	13/16	27/32	7/8	29/32	15/16	31/32	1